

CAPACITY	SYMBOL/ SERIAL NO.	CIRCUIT DIAGRAM
AC 230V		
65W x 1		

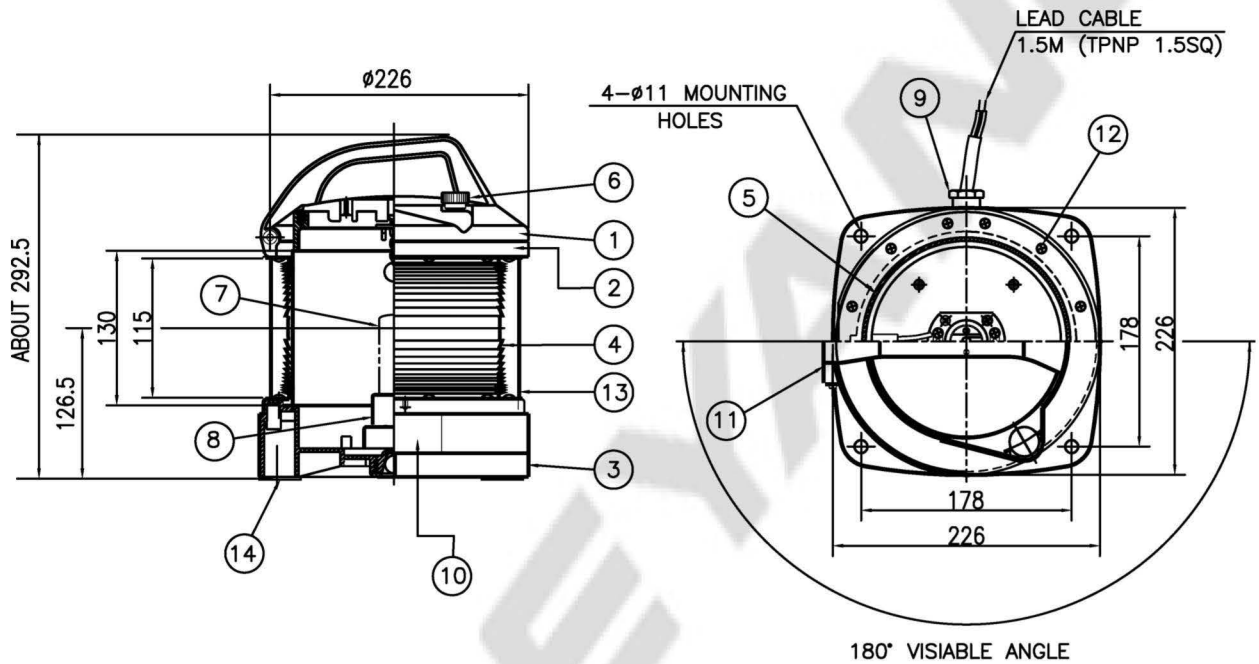

NOTE

1. APPLICATION RANGE : VESSEL OF 50M IN LENGTH AND ABOVE
2. MINIMUM VISIBILITY : 3 N.M

* CAUTION!!
Do not install the navigation light upside down.
Since breathing device is installed on the bottom of fixture.

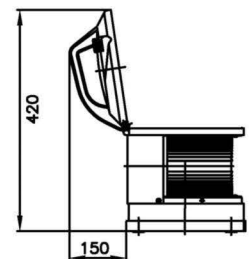

MAINTENANCE SPACE

14	ANTI-VIBRATION PACKING	C.R.	4	5mm	7	NAVIGATION LIGHT LAMP	-	1	P28s
13	SHIELD PLATE	STAINLESS STEEL304	1		6	CLAMP BOLT	BRASS	2	
12	T/H TAPPING SCREW	STAINLESS STEEL304	24	M4	5	GASKET	SILICONE RUBBER	1	
11	HINGE	POLYCAR-BONATE	1		4	LENS	POLYCAR-BONATE	1	DARK CLEAR
10	NAME PLATE	STAINLESS STEEL316L	1		3	BODY	POLYCAR-BONATE	1	
9	CABLE GLAND(#20)	NYLON	1	ø12~ø15	2	TOPPER	POLYCAR-BONATE	1	
8	LAMP HOLDER	PPS	1	P28s	1	COVER	POLYCAR-BONATE	1	
NO	NAME OF PARTS	MATERIAL	Q'TY	REMARKS	NO	NAME OF PARTS	MATERIAL	Q'TY	REMARKS

APPROVED	B. K. KIM	UNIT	MM	TITLE; WHITE LIGHT FOR MARINE USE			
CHECKED		SCALE	N/S				
DRAWING	B. I. KIM	COLOR	MAT BLACK				
DATE	2015.12.04	IP	56				
				MODEL NO.	A2P-SWH6523Hh-1.5M-MED	WEIGHT	2.9 Kg
				DWG NO.	L31150094	SHEET NO.	32